

TAKI[®] – Fixing System



User Manual





TAKI® – Fixing System User Manual

01.01.2010

www.taki.fi

1	DESCRIPTION AND INTENDED USE.....	3
2	LOAD RESISTANCE.....	4
3	INSTALLING TAKI®-CLIP TO THE RAIL.....	4
4	USE OF TAKI®-FIXING SYSTEM.....	5
5	MAINTENANCE AND INSPECTIONS.....	7



1 Description and intended use

TAKI®-Fixing System has been developed to lash the load in vans, trailers and lorries.

TAKI-Fixing System is fixing point in TAKI®-rail which can be moved portable. Load can be lashed with hooks and straps. TAKI®-rail will be attached to a stable location in van or trailer e.g. bodywork.

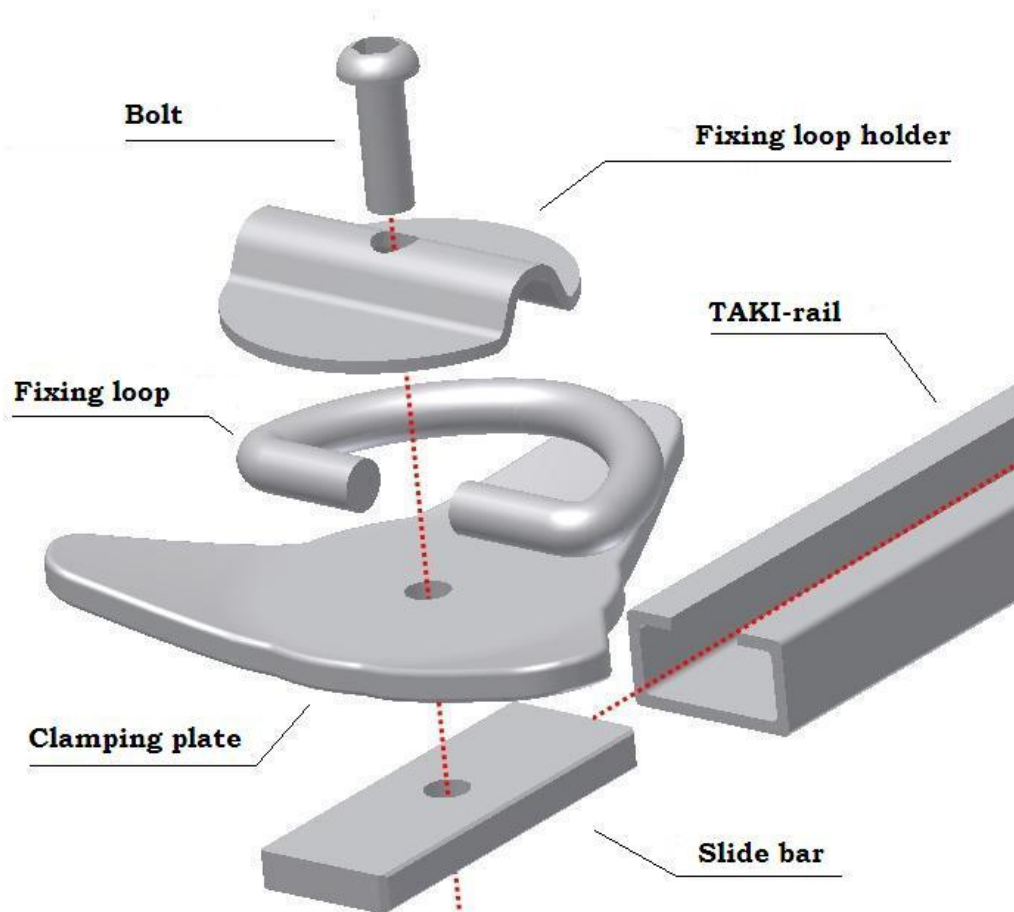

PICTURE 1 Parts of TAKI®-Fixing System



TAKI® – Fixing System User Manual

01.01.2010

www.taki.fi

2 Load resistance

There has been provided A law concerning lashing the load in vehicle. *“Decision of the Ministry of Transport for vehicles load baskets, vehicles loading and lashing the load 14.12.1982 / 940”*. According to that when the vehicle carrying capacity is under 3,5 tons should its nominal strength for lashing points in the wall structure be at least 2,5kN. Lashing point should last two times its nominal strength without breaking so that the strength infected for lashing point in the wall can't deviate no more than 30° from the wall level. TAKI®-Fixing System has been tested in VTT and in HAMK and it has proved its strength by passing the tests.

3 Installing TAKI®-clip to the rail

Install TAKI®-clip to the TAKI®-rail as shown in picture two (2). To open TAKI-clip unscrew the clamping plate as much as you need to put the slide bar in to the TAKI®- rail. After putting the slide bar into the rail put the TAKI®-clip in right place and tighten it.

ATTENTION! When clamping plate is already screwed open do not try to open it more. This could damage the TAKI®-clip.

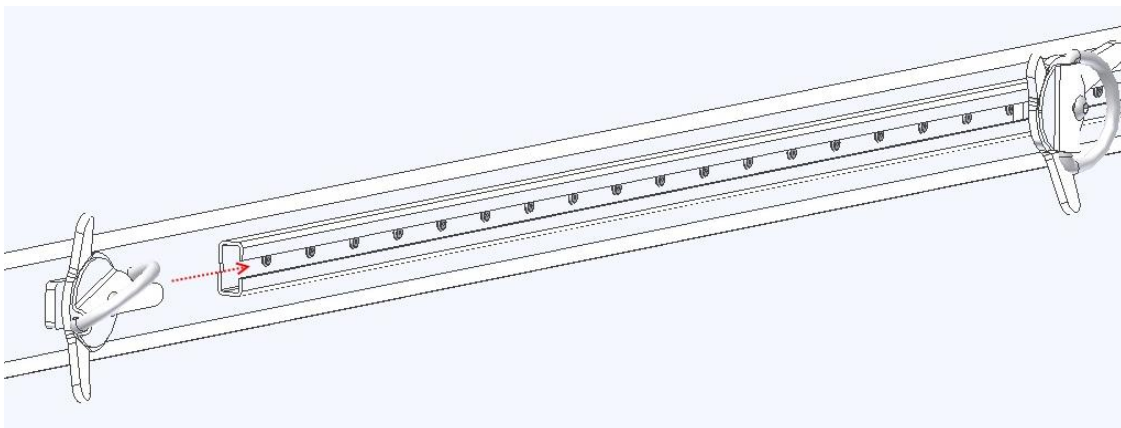

PICTURE 2 Installing TAKI®-clip to the TAKI®-rail



4 Use of TAKI-Fixing System

When you use TAKI®-Fixing System you must always follow these instructions and the Ministry of Transport regulation of loading the vehicle and lashing the load. You must put the load nearby TAKI®-rail and make sure that the TAKI®-clips are at both side of the load (picture 3).

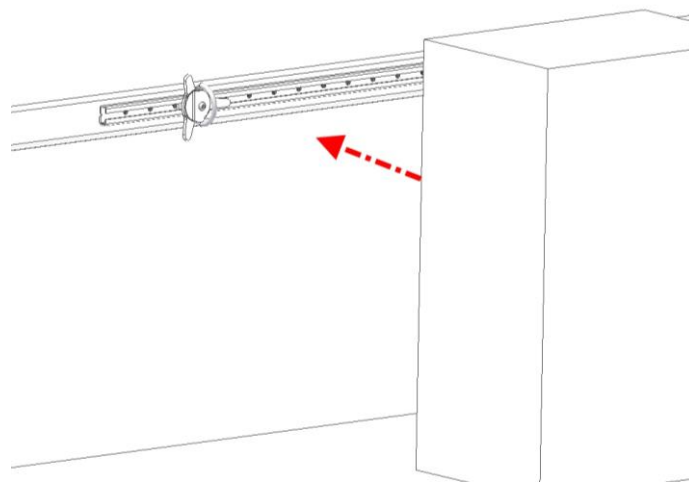

PICTURE 3 Setting the load to the right place.

After the load has been moved to the right place move Taki®-clips as close as possible to the load (picture 4). TAKI®-clips will be tightened with twisting the clamping plate (picture 5).

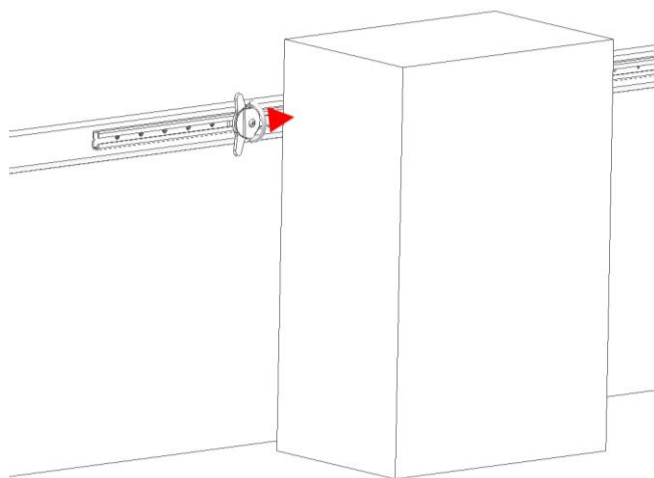

PICTURE 4 move TAKI®-clips as close as possible to the load.



TAKI® – Fixing System User Manual

01.01.2010

www.taki.fi

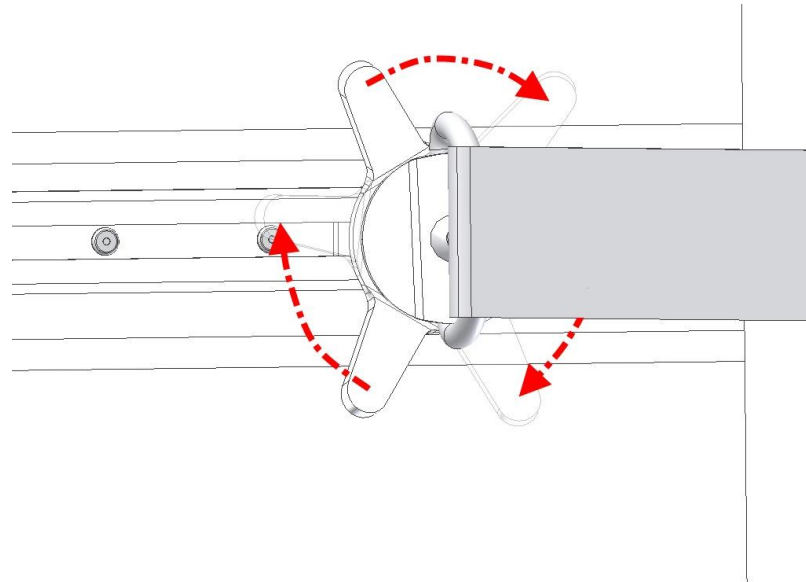

PICTURE 5 Taki®-clip will be tightened with twisting the clamping plate.

Hooks of the strap will be attached with TAKI®-clip fixing loops and strap will be tightened. (picture 6)

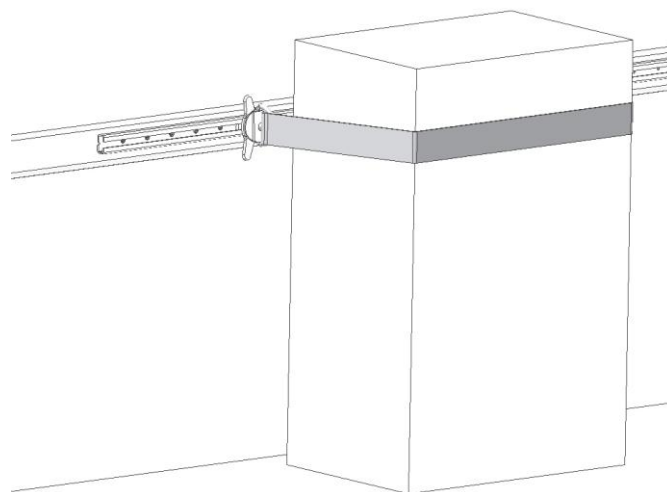

PICTURE 6 Load will be lased with a strap.



In the end make sure that load is firmly attached (picture 7).

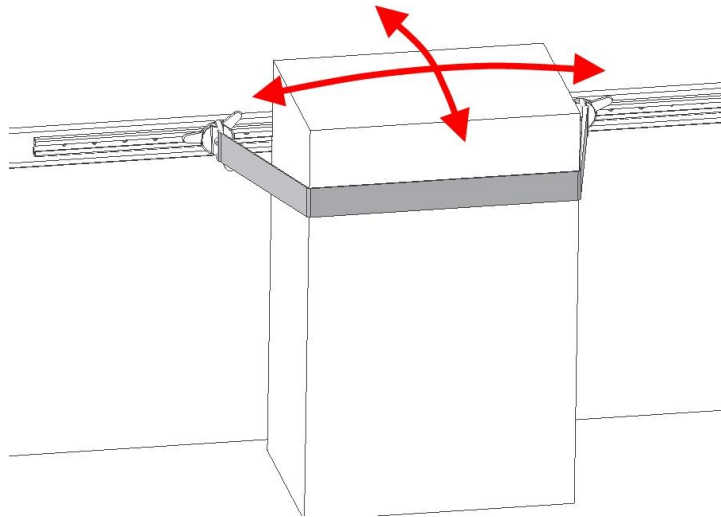

PICTURE 7 Make sure that the load is properly lashed before transportation.

5 Maintenance and inspections

You must always keep all part of TAKI®-Fixing System clean so they are working properly and possible damages can be noticed. The most important is to keep bolts threads and TAKI®- rails clean so the TAKI®-Fixing System is always in planned working condition.

Before using TAKI®-Fixing System you must visually check it. Exceptionally well you must check out that there is no visible deformation or corrosion-induced deterioration in TAKI®-clip or in TAKI®-rail.

Defective, deformed or rusted TAKI®-Fixing System parts may not be used in any case. For using self-repaired parts is strictly prohibited. Defective, deformed or rusted parts must always be replaced with a new one.